



UNIVERSITY OF CAMBRIDGE INTERNATIONAL EXAMINATIONS
General Certificate of Education Ordinary Level

COMBINED SCIENCE

5129/01

Paper 1 Multiple Choice

May/June 2009

1 hour

Additional Materials: Multiple Choice Answer Sheet
 Soft clean eraser
 Soft pencil (type B or HB is recommended)



READ THESE INSTRUCTIONS FIRST

Write in soft pencil.

Do not use staples, paper clips, highlighters, glue or correction fluid.

Write your name, Centre number and candidate number on the Answer Sheet in the spaces provided unless this has been done for you.

There are **forty** questions on this paper. Answer **all** questions. For each question there are four possible answers **A, B, C** and **D**.

Choose the **one** you consider correct and record your choice in **soft pencil** on the separate Answer Sheet.

Read the instructions on the Answer Sheet very carefully.

Each correct answer will score one mark. A mark will not be deducted for a wrong answer.

Any rough working should be done in this booklet.

A copy of the Periodic Table is printed on page 16.

This document consists of **16** printed pages.



- 1 Which instrument is used to measure the volume of an irregularly shaped object?
- A** a measuring cylinder
B a metre rule
C a micrometer
D vernier calipers
- 2 The graph shows how the speed of a car changes with time.

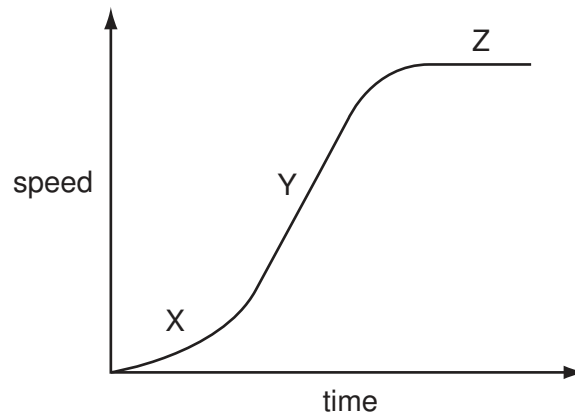

Which statement is correct?

- A** At X, the car has constant acceleration.
B At Y, the car has acceleration which is not constant.
C At Z, the car has constant speed.
D At Z, the car is at rest.
- 3 What are two correct characteristics of mass and weight?

	mass	weight
A	measured in kg	measured in kg
B	measured in N	measured in N
C	can be measured using a spring balance	can be measured using a beam balance
D	can be measured using a beam balance	can be measured using a spring balance

- 4 A metal bar, PQ, has a weight of 5 N and is pivoted at P.

It is held horizontal by a newton meter acting at Q.

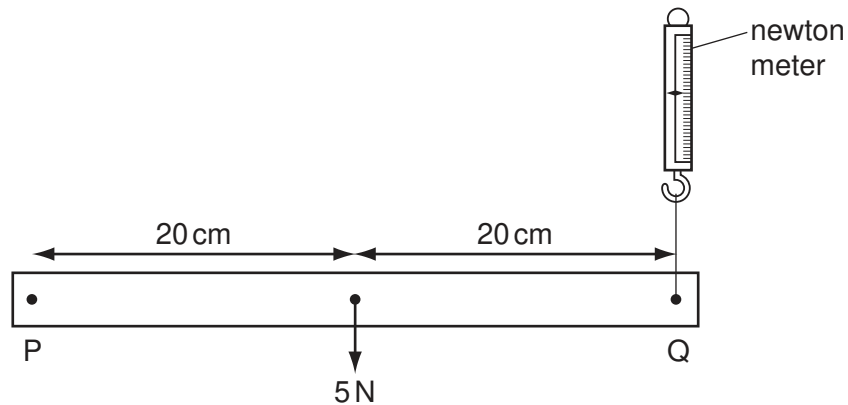

What is the reading on the newton meter?

- A** 2.5 N **B** 5 N **C** 8 N **D** 10 N
- 5 Four electric heating elements convert electrical energy into thermal energy.

Which heating element has the highest power rating?

	energy converted
A	100 J in 5 s
B	200 J in 5 s
C	400 J in 20 s
D	600 J in 20 s

- 6 A clinical thermometer is placed in a person's mouth and then removed to read the temperature.

Why is a clinical thermometer more suitable than a laboratory thermometer for this purpose?

- A** It has a larger range.
B It has a linear scale.
C It has a steady reading.
D It has a wider bore.

7 The diagram shows the outline of a water wave.

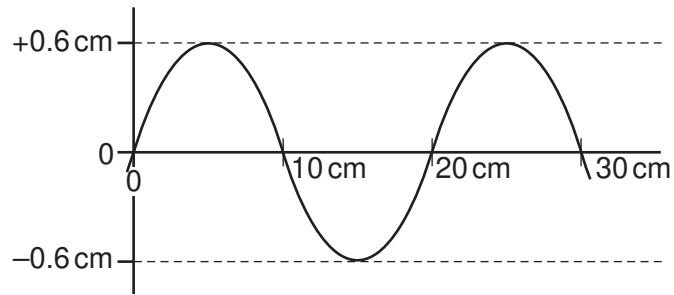

What are the values of the amplitude and the wavelength of the wave?

	amplitude / cm	wavelength / cm
A	0.6	10
B	0.6	20
C	1.2	10
D	1.2	20

8 The ray diagram shows light reflecting off a plane mirror.

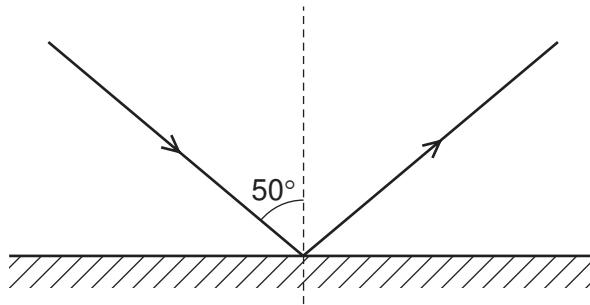

What is the angle between the incident and reflected rays?

- A** 40° **B** 50° **C** 80° **D** 100°

9 An electron is at rest between two charged metal plates as shown in the diagram.

In which direction does the electrostatic force act on the electron?

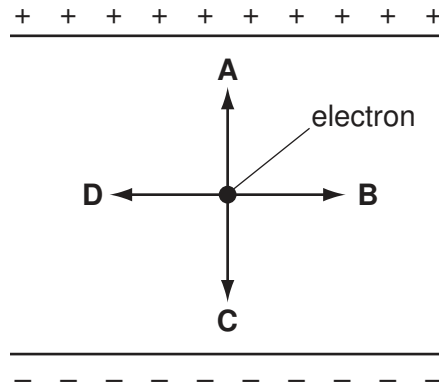

10 In the circuit shown the reading on the ammeter is 1 A.

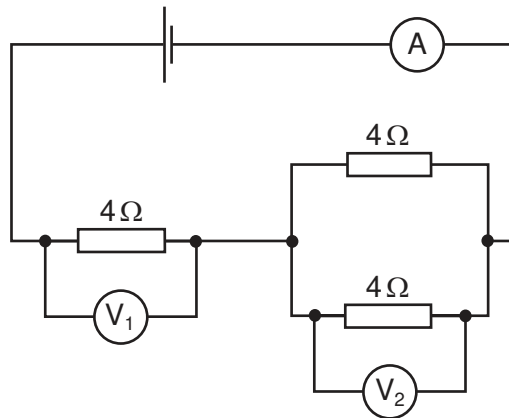

What would be the readings shown by the voltmeters V_1 and V_2 ?

	V_1	V_2
A	2V	2V
B	2V	4V
C	4V	4V
D	4V	2V

11 What is an example of induced magnetism?

- A** a compass needle pointing north
- B** a north pole attracting iron filings
- C** a north pole repelling a north pole
- D** the coil of a generator turning in a magnetic field

12 The diagram represents a nucleus of element X.

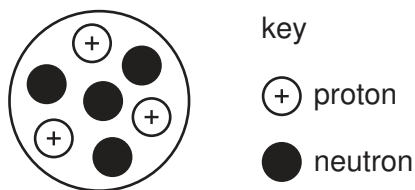

What represents the nuclide of this element?

- A ${}^3_4\text{X}$ B ${}^4_3\text{X}$ C ${}^7_3\text{X}$ D ${}^7_4\text{X}$

13 Which equation represents the decay of the nuclide ${}^{226}_{88}\text{Ra}$ by the emission of an alpha particle?

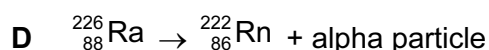
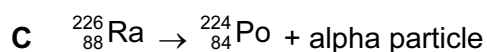
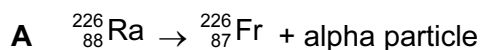

14 The diagram shows a mixture of water and alcohol being separated by distillation.

Where are the molecules furthest apart?

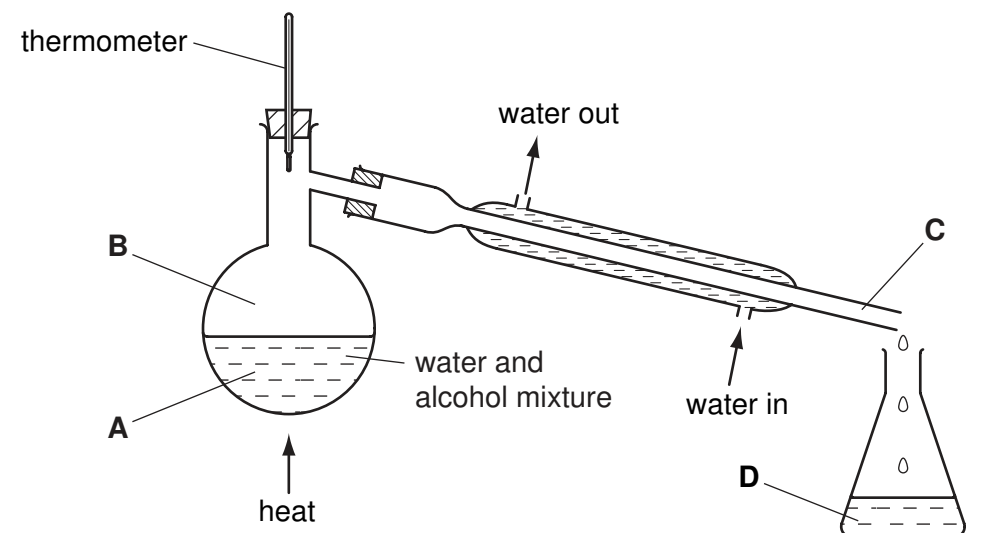

15 What do isotopes of the same element contain?

- A the same number of electrons and protons but differing numbers of neutrons
 B the same number of electrons and neutrons but differing numbers of protons
 C the same number of protons and neutrons but differing numbers of electrons
 D the same number of electrons, protons and neutrons

16 The table shows some properties of four substances.

Which substance could be sodium chloride?

	melting point/°C	ability to conduct electricity when liquid	ability to conduct electricity in aqueous solution
A	-114	none	good
B	180	none	poor
C	808	good	good
D	3550	good	poor

17 Elements X and Y combine to form the gas XY_2 .

What are X and Y?

	X	Y
A	calcium	chlorine
B	carbon	hydrogen
C	carbon	oxygen
D	hydrogen	oxygen

18 5.2 g of a metal M, $A_r = 52$, combine with 2.4 g of oxygen.

What is the formula of the oxide formed?

- A** MO **B** MO₂ **C** M₂O **D** M₂O₃

19 Waste water from a factory was found to have a pH value of 2.

Which substance could be used to neutralise the waste water before it is released into a river?

- A** ammonium sulfate
B lime
C oxygen
D sulfur dioxide

20 Rubidium is in Group I of the Periodic Table.

What are properties of rubidium chloride?

	formula	approximate melting point / °C	solubility in water
A	RbCl	70	insoluble
B	RbCl	700	soluble
C	RbCl ₂	70	soluble
D	RbCl ₂	700	insoluble

21 Which statement indicates that sodium is a metal?

- A** It is a good conductor of electricity.
- B** It is soft.
- C** It burns readily in air.
- D** It floats on water.

22 Metal X reacts with the oxide of metal Y, but not with the oxide of metal Z.

What is the order of reactivity of the metals X, Y and Z?

	most reactive → least reactive		
A	X	Z	Y
B	Y	X	Z
C	Z	X	Y
D	Z	Y	X

23 Three identical iron nails are treated in various ways before being put into tap water in separate test-tubes.

nail 1 covered in grease

nail 2 galvanised

nail 3 painted on one side not the other

Which nails will rust after a week in the tap water?

- A** 1 and 3
- B** 2 only
- C** 2 and 3
- D** 3 only

24 Which conditions would produce the best yield of ammonia in the Haber process?

	temperature / °C	pressure / atm	catalyst
A	400	20	platinum
B	400	200	iron
C	40	20	none
D	40	200	platinum

25 The melting-point range of four fractions from the distillation of petroleum is given below.

Which fraction would be suitable for making road surfaces?

- A** -20° to 0°C
- B** 0° to 25°C
- C** 25° to 45°C
- D** 45° to 70°C

26 Similar amounts of some fats and oils are dissolved in a solvent.

A few drops of aqueous bromine are added and each mixture is shaken. The table shows the results.

Which fat or oil is the highest in polyunsaturates?

	fat or oil	colour of mixture
A	butter	dark orange
B	lard	orange
C	margarine	yellow
D	vegetable oil	colourless

27 The diagram shows a reaction scheme.

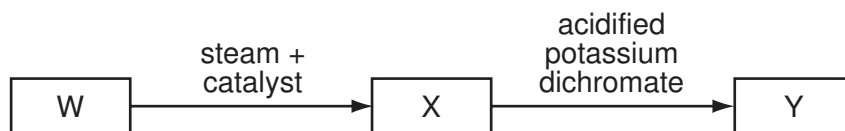

The empirical formula of Y is CH_2O .

Which compounds do W, X and Y represent?

	W	X	Y
A	ethane	ethanol	ethanoic acid
B	ethene	ethanol	ethanoic acid
C	propene	propanol	propanoic acid
D	butene	butanol	butanoic acid

28 Which structure in the plant cell contains chromosomes?

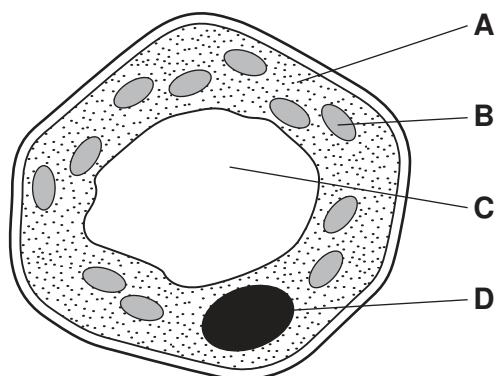

29 What is a function of some enzymes in a seed during germination?

- A** breaking down insoluble food into soluble substances
- B** increasing the rate of photosynthesis
- C** increasing water absorption
- D** making starch for storage

- 30 The diagram shows a photosynthesis investigation. The plant has leaves that are green in the middle and white round the edges.

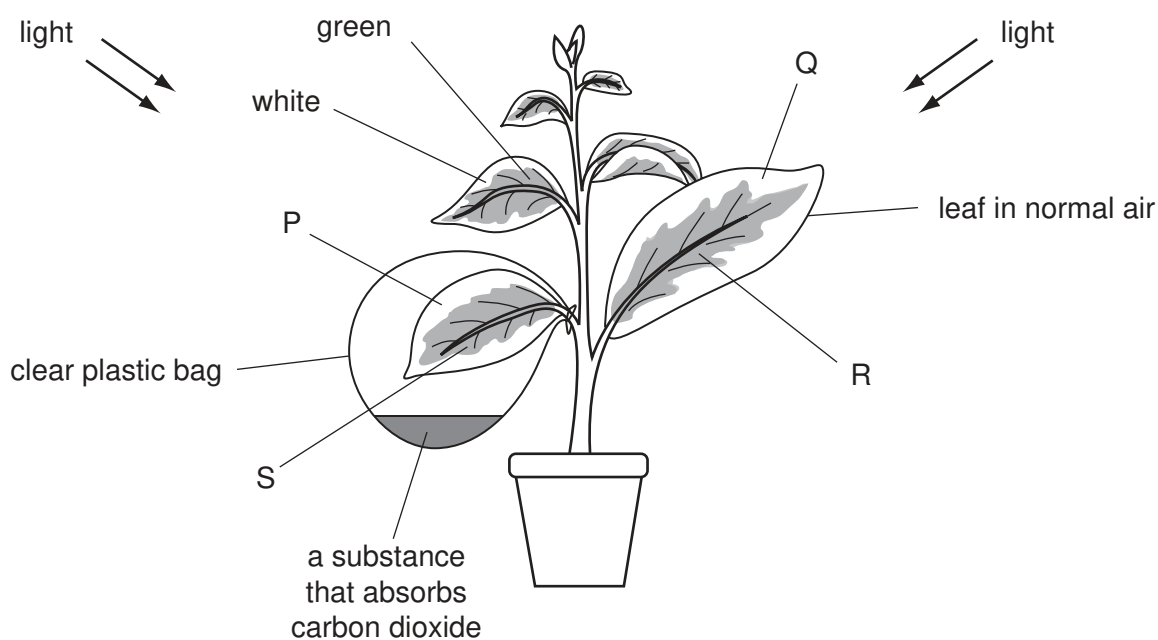

Which leaf areas lack only **one** factor needed for photosynthesis?

- A P and Q B P and R C Q and S D R and S
- 31 The table shows the average daily energy needed for adult males and females involved in different activities.

activity	energy needed in MJ	
	males	females
lying in bed	7	6
watching TV	8	7
light work	11	9
heavy work	15	13

What can be concluded from these data?

- A Males do more work than females.
 B Males need more energy than females to do the same activity.
 C The energy requirement depends only upon the activity.
 D The energy requirement depends only upon the person's sex.

32 What causes wilting to occur in a plant?

	water loss	water uptake
A	high	high
B	high	low
C	low	high
D	low	low

33 The diagram shows a vertical section through the human heart.

Which structure separates oxygenated blood from deoxygenated blood?

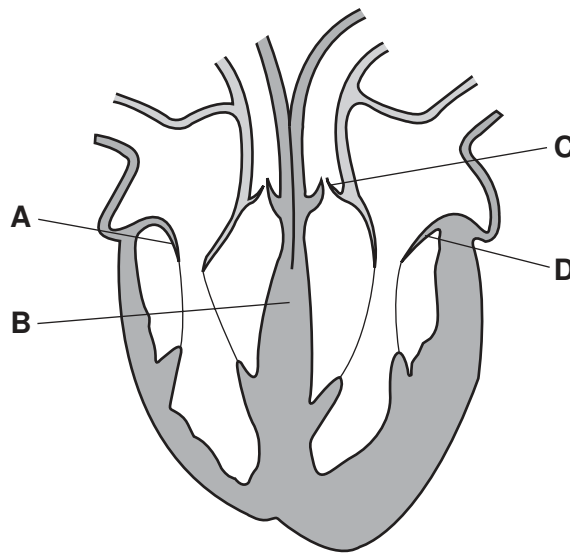

34 The diagram shows apparatus used to investigate respiration.

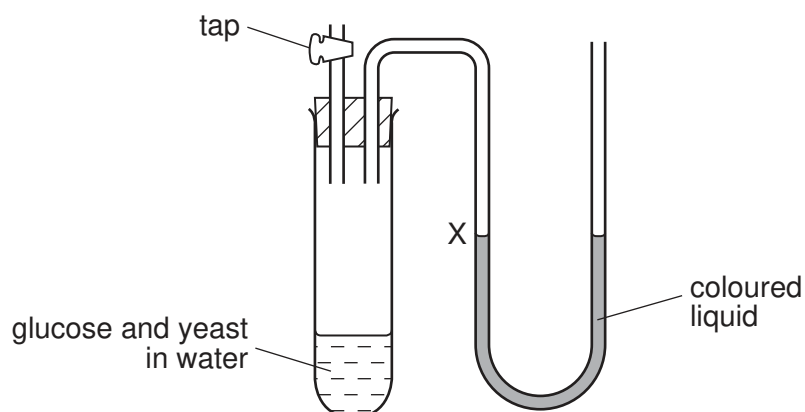

The tap is closed and the yeast respire anaerobically.

What is observed at X and which explanation is correct?

	observation at X	explanation
A	liquid level falls	carbon dioxide is produced
B	liquid level falls	oxygen is used
C	liquid level rises	carbon dioxide is produced
D	liquid level rises	oxygen is used

35 An antelope is grazing under a tree. It hears men shouting in the distance.

Which changes take place in the antelope's eyes as it raises its head to look at the men?

	ciliary body	suspensory ligament	lens
A	contracts	becomes taut	becomes more convex
B	contracts	becomes slack	becomes less convex
C	relaxes	becomes taut	becomes less convex
D	relaxes	becomes slack	becomes more convex

36 What effects are likely if alcohol intake is excessive?

	short term effects	long term effects
A	acts as a stimulant	weight loss
B	aids digestion	extra energy
C	improves co-ordination	cancer
D	slows reactions	liver damage

37 The diagram shows the flow of energy in a typical ecosystem.

Which box represents organisms with the greatest amount of energy flowing through them?

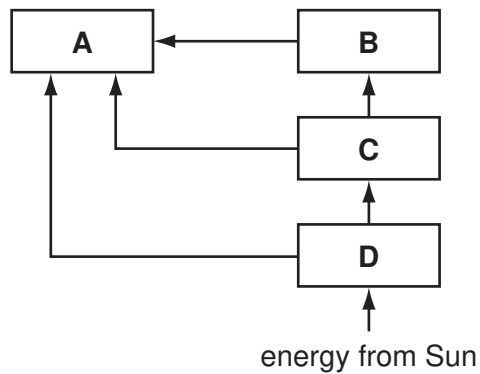

38 What does **not** contribute to famine?

- A decreased population
- B drought
- C flooding
- D unequal distribution of food

39 The diagram shows some seeds in a pea pod.

Which structure is the pericarp?

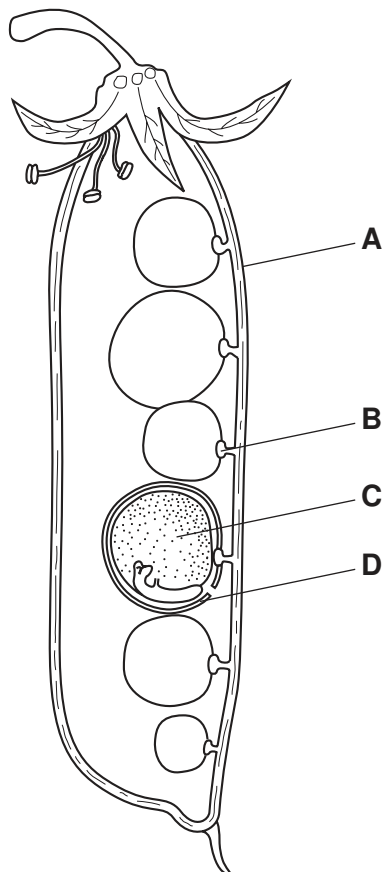

- 40 Which method of birth control acts by preventing the implantation of the fertilised egg?
- A coil (mechanical)
 - B condom (mechanical)
 - C spermicide (chemical)
 - D vasectomy (surgical)

DATA SHEET
The Periodic Table of the Elements

		Group												
I	II	III	IV	V	VI	VII	0							
		1 H Hydrogen 1											4 He Helium 2	
7 Li Lithium 3	9 Be Beryllium 4											20 Ne Neon 10		
23 Na Sodium 11	24 Mg Magnesium 12	27 Al Aluminium 13	28 Si Silicon 14	31 P Phosphorus 15	32 S Sulfur 16	35.5 Cl Chlorine 17	40 Ar Argon 18							
39 K Potassium 19	40 Ca Calcium 20	70 Ga Gallium 31	73 Ge Germanium 32	75 As Arsenic 33	79 Se Selenium 34	80 Br Bromine 35	84 Kr Krypton 36							
85 Rb Rubidium 37	88 Sr Strontium 38	115 In Indium 49	119 Sn Tin 50	122 Sb Antimony 51	128 Te Tellurium 52	127 I Iodine 53	131 Xe Xenon 54							
133 Cs Caesium 55	137 Ba Barium 56	204 Tl Thallium 81	207 Pb Lead 82	209 Bi Bismuth 83	210 Po Polonium 84	210 At Astatine 85	222 Rn Radon 86							
226 Ra Radium 88	227 Ac Actinium 89													
<p>*58-71 Lanthanoid series †90-103 Actinoid series</p>														
<table style="width: 100%; border-collapse: collapse;"> <tr> <td style="border: 1px solid black; padding: 5px;">a</td> <td style="border: 1px solid black; padding: 5px;">X</td> <td style="border: 1px solid black; padding: 5px;">b</td> </tr> </table> <p>Key a = relative atomic mass X = atomic symbol b = proton (atomic) number</p>												a	X	b
a	X	b												
140 Ce Cerium 58	141 Pr Praseodymium 59	144 Nd Neodymium 60	150 Sm Samarium 62	152 Eu Europium 63	157 Gd Gadolinium 64	162 Dy Dysprosium 66	165 Ho Holmium 67	167 Er Erbium 68	169 Tm Thulium 69	173 Yb Ytterbium 70	175 Lu Lutetium 71			
232 Th Thorium 90	238 U Uranium 92	238 Pa Protactinium 91	238 Np Neptunium 93	238 Pu Plutonium 94	238 Am Americium 95	238 Cm Curium 96	238 Bk Berkelium 97	238 Cf Californium 98	238 Es Einsteinium 99	238 Fm Fermium 100	238 Md Mendelevium 101	238 No Nobelium 102	238 Lr Lawrencium 103	

The volume of one mole of any gas is 24 dm³ at room temperature and pressure (r.t.p.).

Permission to reproduce items where third-party owned material protected by copyright is included has been sought and cleared where possible. Every reasonable effort has been made by the publisher (UCLES) to trace copyright holders, but if any items requiring clearance have unwittingly been included, the publisher will be pleased to make amends at the earliest possible opportunity.

University of Cambridge International Examinations is part of the Cambridge Assessment Group. Cambridge Assessment is the brand name of University of Cambridge Local Examinations Syndicate (UCLES), which is itself a department of the University of Cambridge.